

DL4000 VIDEO TRANSPORT SYSTEM

Optical Multiplexers

DWDM, CWDM and WDM Optical Multiplexing Modules



Features

Single Slot Modules*

Optical Multiplexing Features

- Enables up to 160 video services over a single fiber
- Bi-Directional
- Passive design for reliability
- Industry Standard ITU wavelengths
- Industry Standard LC/PC Connectors
- Modules include expansion port (passes all other wavelengths)
- Low Optical Losses
- Compatible with DL4000, DL4042, DL4100, and DL4000P chassis

DWDM Features

- Industry standard ITU G.694.1 wavelengths
- Optically multiplex up to 40 channels on a single fiber
- 8 wavelengths plus expansion port per module
- Interconnect modules for up to 32 channels in a DL4000 Chassis
- 20 and 40 Channel versions use single rack unit integrated chassis

CWDM Features

- Industry standard ITU G.694.2 wavelengths
- Up to 8 wavelengths plus expansion port per module
- Multiple 4 Channel options
 - Low (1471nm, 1491nm, 1511nm, 1531nm)
 - High (1551nm, 1571nm, 1591nm, 1611nm)
 - Mid (1511nm, 1531nm, 1571nm, 1591nm)
 - Outer (1471nm, 1491nm, 1591nm, 1611nm)

WDM Features

- 1310nm and 1550nm combiner/splitters
- Single or dual modular versions
- External version conserves chassis slot

* 20 and 40 Channel models are integrated into a 1RU chassis

Artel's DWDM, CWDM and WDM modules create a comprehensive set of optical multiplexing solutions for the DL4000 Video Transport System. These modules, in conjunction with other DL4000 modules or third party equipment, allow the creation of flexible, space and fiber efficient optical networks.

Artel designed its optical multiplexing products to address the issue of space and fiber constraint. For space efficiency, each module takes only one bay in a DL4000 based chassis. Utilizing industry standard optical filters plus additional expansion port, or complex optical networks can be created. Completely passive, and designed with the latest optical filters, Artel's DWDM, CWDM and WDM modules are extremely reliable, cost effective, and feature low insertion losses.

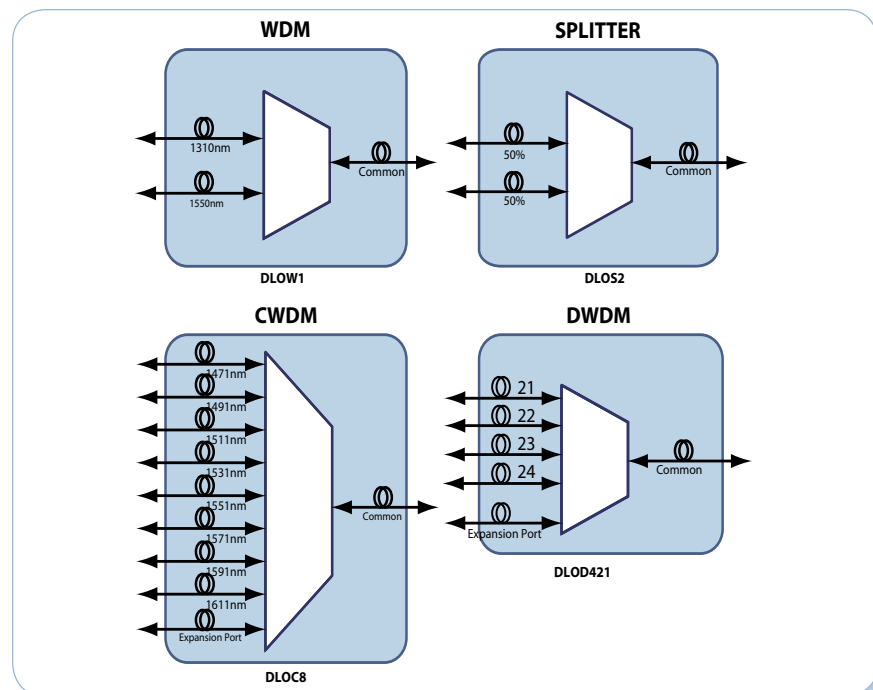

WDM Ordering Information and Specifications | 1310nm and 1550nm

Model #	Description	Part #	# Channels	Channels	Insertion Loss	Isolation	Return Loss	Insertion Loss Upgrade Port
DLOW1	Single WDM	390-008754-01	2	1310, 1550	≤1.3 dB	≥ 30dB	≥ 40dB	≤ 2.1 dB
DLOW2	Dual WDM	390-008754-02	2	1310, 1550	"	"	"	"
DLOWE	External WDM	390-008790-15	2	1310, 1550	"	"	"	"

CWDM Ordering Information and Specifications | Channels 1471 through 1611 of ITU G694.2

Model #	Part #	# Chans	Channels	Insertion Loss (±7.0 nm)	Isolation (±7.0 nm)	Directivity	Return Loss	Insertion Loss Upgrade Port
DLOC4L	390-008752-00	4	1471, 1491, 1511, 1531	≤ 2.1 dB	≥ 30dB	≥ 40dB	≥ 40dB	≤ 2.1 dB
DLOC4M	390-008752-01	4	1511, 1531, 1551, 1571	"	"	"	"	"
DLOC4H	390-008752-02	4	1551, 1571, 1591, 1610	"	"	"	"	"
DLOC40	390-008752-03	4	1471,1491, 1591, 1611	"	"	"	"	"
DLOC8	390-008752-04	8	1471, 1491, 1511, 1531, 1551, 1571, 1591, 1611	≤ 3.2 dB	"	"	"	"

DWDM Ordering Information and Specifications | Channels 21 through 60 of ITU G694.1

Model #	Part #	# Chans	Channels	Insertion Loss (±0.11 nm)	Passband Flatness (±0.11 nm)	Isolation (±0.11 nm)	Directivity	Return Loss	Uniformity	Insertion Loss Upgrade Port
DLOD421	390-008762-21	4	21, 22, 23, 24	≤ 2.4 dB	≤ 0.5 dB	≥ 25dB	≥ 40dB	≥ 40dB	≤ 1.0 dB	≤ 1.7 dB
DLOD425	390-008762-25	4	25, 26, 27, 28	"	"	"	"	"	"	"
DLOD429	390-008762-29	4	29, 30, 31, 32	"	"	"	"	"	"	"
DLOD433	390-008762-33	4	33, 34, 35, 36	"	"	"	"	"	"	"
DLOD437	390-008762-37	4	37, 38, 39, 40	"	"	"	"	"	"	"
DLOD441	390-008762-41	4	41, 42, 43, 44	"	"	"	"	"	"	"
DLOD445	390-008762-45	4	45, 46, 47, 48	"	"	"	"	"	"	"
DLOD449	390-008762-49	4	49, 50, 51, 52	"	"	"	"	"	"	"
DLOD453	390-008762-53	4	53, 54, 55, 56	"	"	"	"	"	"	"
DLOD457	390-008762-57	4	57, 58, 59, 60	"	"	"	"	"	"	"
DLOD821	390-008763-21	8	21 thru 28 @ 100GHz Spacing	≤ 3.5 dB	"	"	"	"	"	≤ 2.9 dB
DLOD829	390-008763-29	8	29 thru 36 @ 100GHz Spacing	"	"	"	"	"	"	"
DLOD837	390-008763-37	8	37 thru 44 @ 100GHz Spacing	"	"	"	"	"	"	"
DLOD845	390-008763-45	8	45 thru 52 @ 100GHz Spacing	"	"	"	"	"	"	"
DLOD853	390-008763-53	8	53 thru 60 @ 100GHz Spacing	"	"	"	"	"	"	"
DLOD2021*	390-008766-21	20	21-40 @ 100 GHz Spacing	≤ 4.6 dB	"	"	"	"	"	≤ 4.0 dB
DLOD2041*	390-008766-41	20	41-60 @ 100 GHz Spacing	"	"	"	"	"	"	"
DLOD4021*	390-008767-21	40	21-60 @ 100 GHz Spacing	≤ 6.1 dB	"	"	"	"	"	N/A

*Integrated one piece chassis

Dual Window Wide Band Optical Splitters Ordering Information and Specifications

Model #	Description	Part #	Port 1	Ratio	Port 2	Port 1 Insertion Loss Port 2
DLOS2	50/50 Optical Splitter	390-008753-00	50%		50%	4.0 dB 4.0 dB
DLOS2-01	1/99 Optical Splitter	390-008753-01	1%		99%	23.0 dB 1.0 dB
DLOS2-05	5/95 Optical Splitter	390-008753-05	5%		95%	15.0 dB 1.0 dB
DLOS2-10	10/90 Optical Splitter	390-008753-10	10%		90%	12.0 dB 1.5 dB
DLOS2-20	20/80 Optical Splitter	390-008753-20	20%		80%	8.5 dB 2.0 dB
DLOS2-30	30/70 Optical Splitter	390-008753-30	30%		70%	6.5 dB 2.5 dB
DLOS2-40	40/60 Optical Splitter	390-008753-40	40%		60%	5.0 dB 3.5 dB